

		Parts List	
ITEM	PART #	DESCRIPTION	NOTES
1	K1580-50	Series 7 1/4 Round Body Assembly	Slide assembly into post
2	1550	Series 7 Reveal	Attached to body
3	K1500-50	Series 7 Radius Post Assembly	
4	Post Cap	Series 7 Radius Post Cap	Zero Reveal Part #5020, 1/2" Reveal Part #5024, 1" Reveal Part #5026
41	5040	Cap Screw	2 - #10 x 1/2" counter sunk phillips head screws

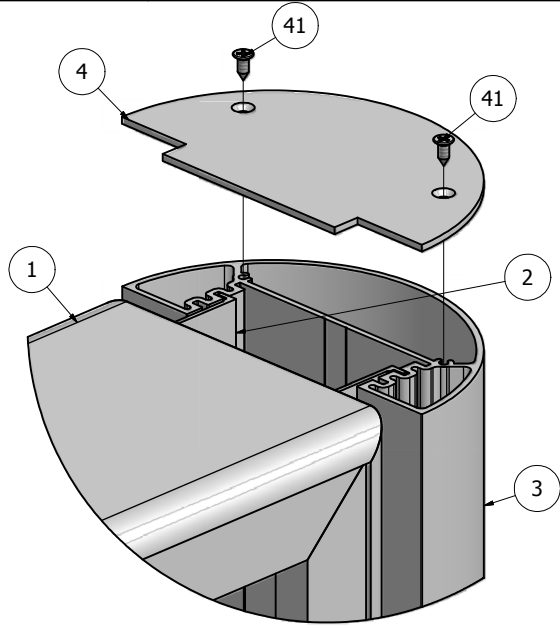

DETAIL A

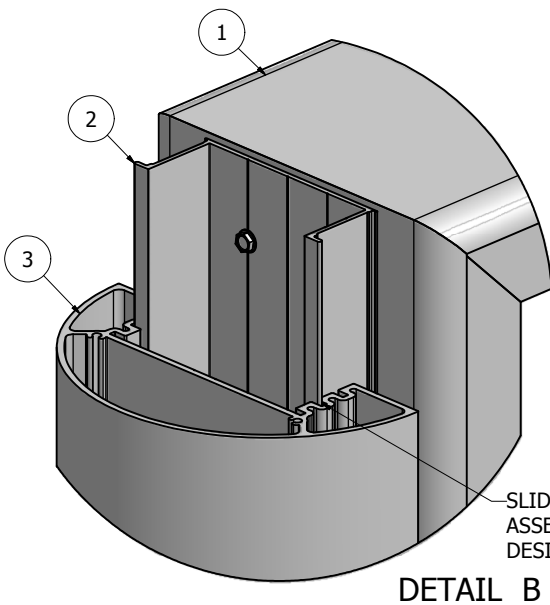
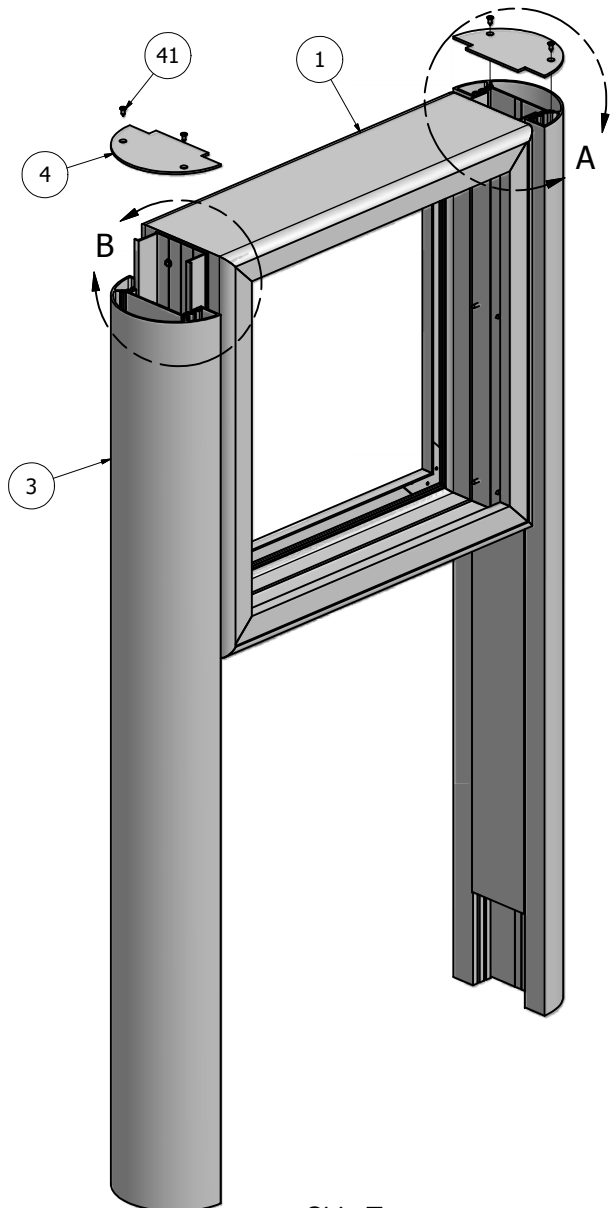
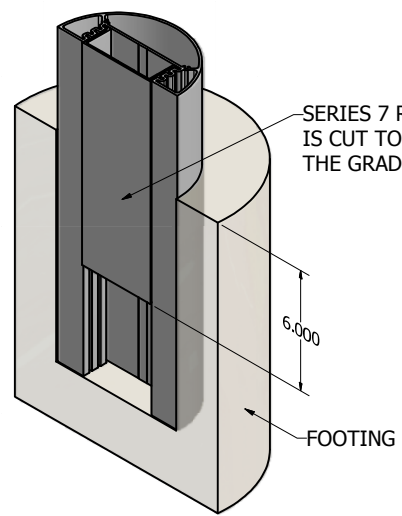
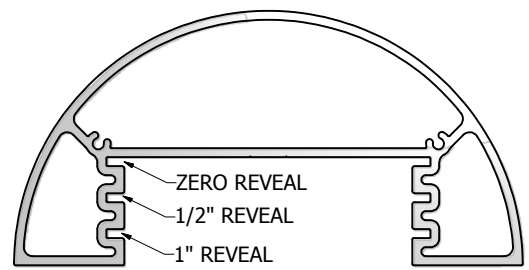

SERIES 7 REVEAL/FILLER IS CUT TO FIT 6" BELOW THE GRADE.

NOTE: PRE-CUT KITS ARE NOT PRE-DRILLED.
 (Holes shown in this drawing are for reference only.
 Drilling of pilot holes are to be done by fabricator.)

Ship To:
 Order #:

THIS DRAWING WAS CREATED AT NO CHARGE TO ASSIST YOU IN VISUALIZING OUR PROPOSAL. THE DRAWING HEREIN IS THE PROPERTY OF SIGNCOMP. PERMISSION TO COPY OR REVISE THIS DRAWING OR TO USE THIS DRAWING FOR PRODUCTION IS STRICTLY PROHIBITED AND CAN ONLY BE COPIED, REVISED OR USED FOR PRODUCTION WITH THE EXPRESSED WRITTEN PERMISSION OF SIGNCOMP.			
DRAWN	12/9/2009	SignComp	
Steve			
CHECKED		TITLE	
QA		Series 7 1/4 Round Body - Series 7 Radius Post - Assembly	
MFG		SIZE	DWG NO
APPROVED		C	K1580-00-50
		SCALE	REV
			SHEET 1 OF 1

Parts List			
ITEM	PART #	DESCRIPTION	NOTES
1	1580	Series 7, 1/4 Round Body	Top & Bottom
2	1580	Series 7, 1/4 Round Body	Sides
3	5210	Corner Key	

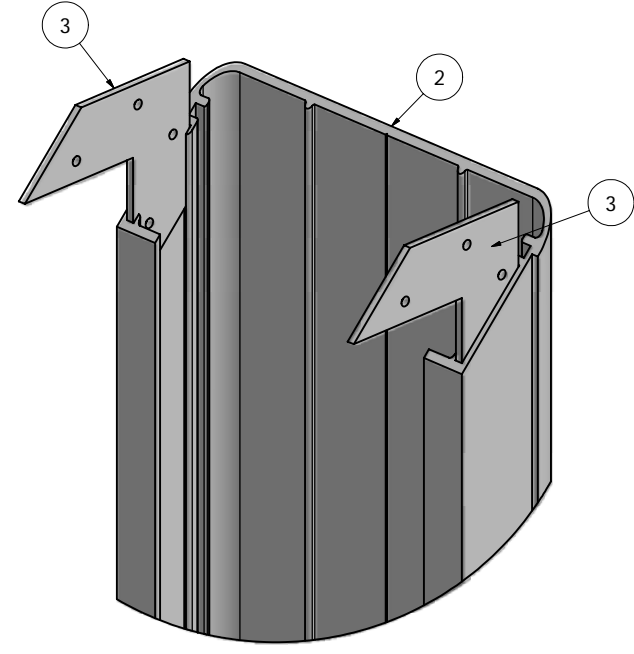
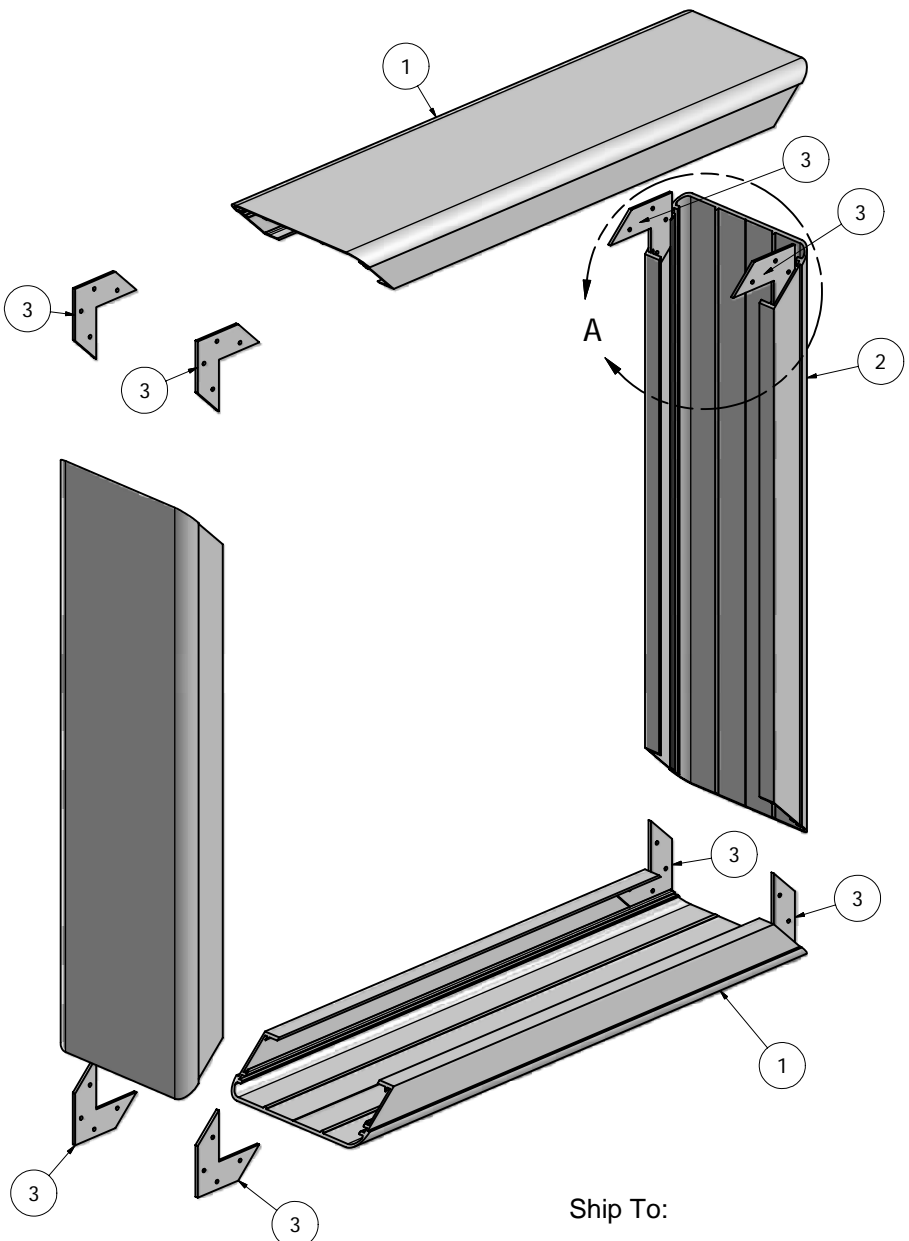

DETAIL A

NOTE: PRE-CUT KITS ARE NOT PRE-DRILLED.
 (Holes shown in this drawing are for reference only.
 Drilling of pilot holes are to be done by fabricator.)

THIS DRAWING WAS CREATED AT NO CHARGE TO ASSIST YOU IN VISUALIZING OUR PROPOSAL. THE DRAWING HEREIN IS THE PROPERTY OF SIGNCOMP. PERMISSION TO COPY OR REVISE THIS DRAWING OR TO USE THIS DRAWING FOR PRODUCTION IS STRICTLY PROHIBITED AND CAN ONLY BE COPIED, REVISED OR USED FOR PRODUCTION WITH THE EXPRESSED WRITTEN PERMISSION OF SIGNCOMP.			
DRAWN	2/6/2009	<h1>SignComp</h1> <p>Series 7, 1/4 Round Body - Assembly</p>	
CHECKED			
QA			
MFG			
APPROVED			
	SIZE	DWG NO	REV
	C	K1580	
	SCALE	SHEET 1 OF 1	

Ship To:
 Order #:

Parts List			
ITEM	PART #	DESCRIPTION	NOTES
1	1580	Series 7, 1/4 Round Body	Assembly
2	1550	Series 7 Reveal	Attach to 1/4 Round Body
3	5220	Reveal to Body Screw	Drill 3/32" Pilot Hole in pairs 12" OC

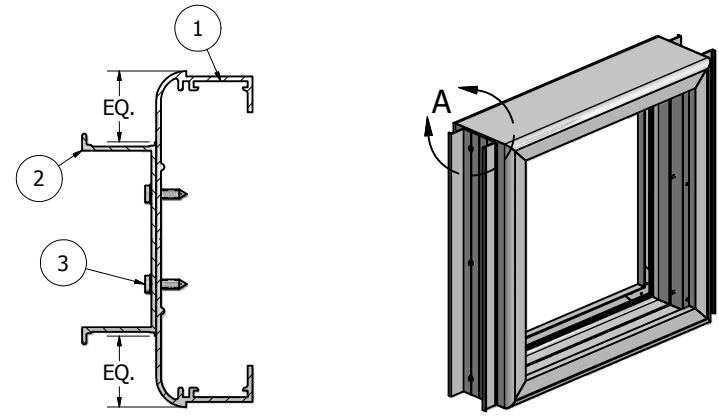
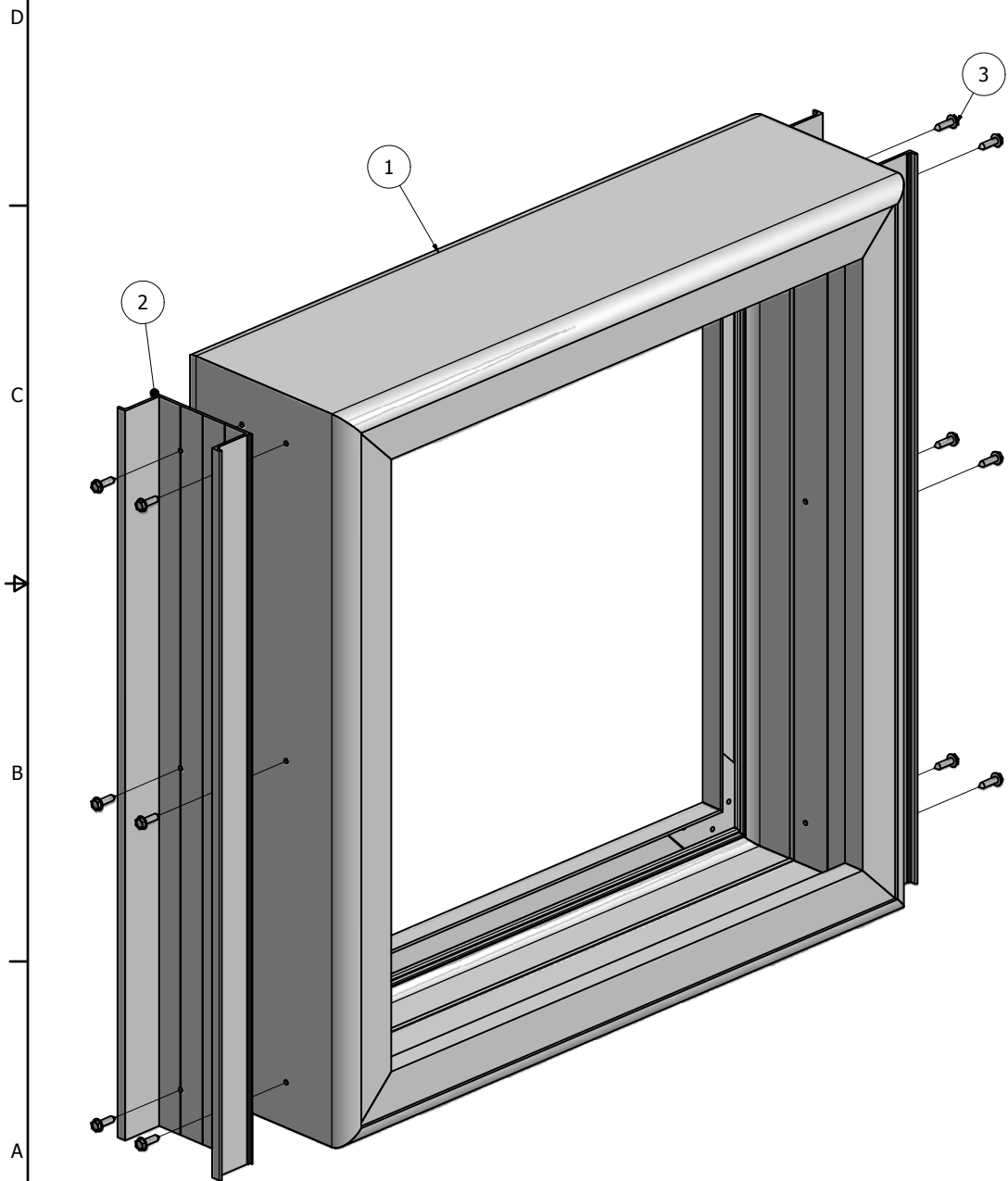

SECTION B-B

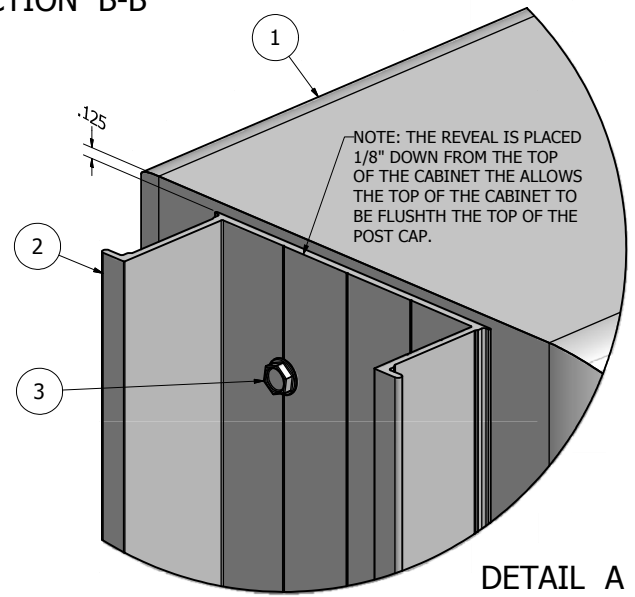

NOTE: THE REVEAL IS PLACED 1/8" DOWN FROM THE TOP OF THE CABINET THE ALLOWS THE TOP OF THE CABINET TO BE FLUSH WITH THE TOP OF THE POST CAP.

DETAIL A

NOTE: PRE-CUT KITS ARE NOT PRE-DRILLED.
 (Holes shown in this drawing are for reference only.
 Drilling of pilot holes are to be done by fabricator.)

Ship To:
 Order #:

THIS DRAWING WAS CREATED AT NO CHARGE TO ASSIST YOU IN VISUALIZING OUR PROPOSAL. THE DRAWING HEREIN IS THE PROPERTY OF SIGNCOMP. PERMISSION TO COPY OR REVISE THIS DRAWING OR TO USE THIS DRAWING FOR PRODUCTION IS STRICTLY PROHIBITED AND CAN ONLY BE COPIED, REVISED OR USED FOR PRODUCTION WITH THE EXPRESSED WRITTEN PERMISSION OF SIGNCOMP.

DRAWN	8/5/2009	SignComp	
CHECKED			
QA		TITLE	
MFG		K1580 with Series 7 Reveal - Reveal Attachment Detail	
APPROVED		SIZE	DWG NO
		C	K1580-50
		SCALE	REV

SHEET 1 OF 1

Parts List			
ITEM	PART #	DESCRIPTION	NOTES
1	1500	Series 7 Radius Post	
2	1550	Series 7 Reveal/Filler	Tack weld or mechanically fasten to post

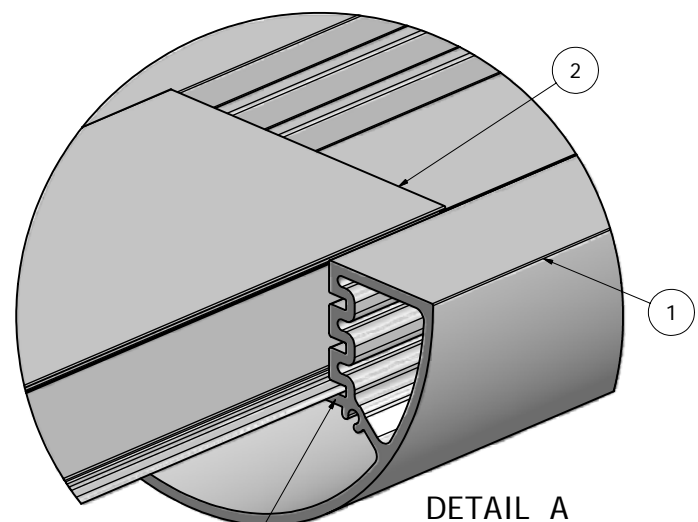
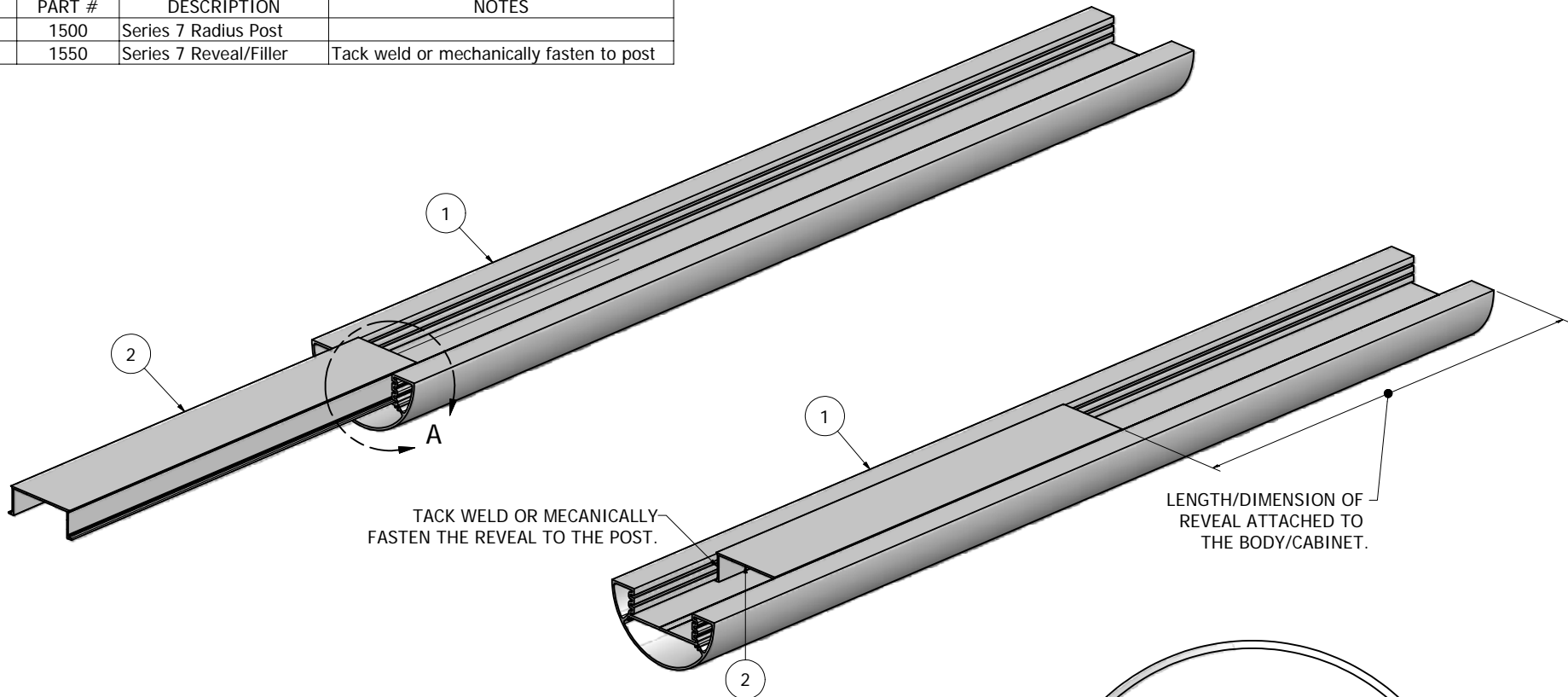

INSERT THE REVEAL/FILLER INTO THE ZERO REVEAL POSTION. SLIDED IT UP INTO THE POST.

Ship To:
Order #:

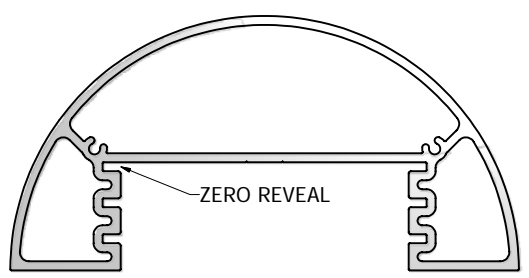

NOTE: PRE-CUT KITS ARE NOT PRE-DRILLED.
(Holes shown in this drawing are for reference only. Drilling of pilot holes are to be done by fabricator.)

THIS DRAWING WAS CREATED AT NO CHARGE TO ASSIST YOU IN VISUALIZING OUR PROPOSAL. THE DRAWING HEREIN IS THE PROPERTY OF SIGNCOMP. PERMISSION TO COPY OR REVISE THIS DRAWING OR TO USE THIS DRAWING FOR PRODUCTION IS STRICTLY PROHIBITED AND CAN ONLY BE COPIED, REVISED OR USED FOR PRODUCTION WITH THE EXPRESSED WRITTEN PERMISSION OF SIGNCOMP.

DRAWN	8/5/2009	SignComp	
Steve			
CHECKED		TITLE	
QA		Series 7 Radius Post and Reveal/Filler Assembly	
MFG		SIZE	DWG NO
APPROVED		C	K1500-50
		SCALE	REV
			SHEET 1 OF 1